



# SYNERGY

Mid-rise building-supported elevators





# CONTENTS

## 04

Speed. Innovation. Freedom.

---

Remarkable ride quality powered by advanced technology **05**

---

## 06

Simple yet sophisticated

---

Standard and upgraded cab designs **07**

---

## 8

Finishes

---

Fixtures and accessories **10**

Entrance and return options **11**

---

## 12

Planning

---

Passenger elevator applications **13**

Service elevator applications **14**

Control rooms **15**

---



# Speed. Innovation. Freedom.

To meet the varying demands of mid-rise buildings, the synergy elevator provides increased flexibility in configuration, load capacity and speed.

The pre-engineered machine room-less (MRL) design saves building space. If building code restricts the in-jamb MRL design, options for a control closet configuration is available. This elevator system uses typical rounded steel cables instead of flat coated, steel belts. synergy features a state-of-the art, 32-bit microprocessor-driven control system plus an advanced regenerative drive system, which captures unused power and feeds it back into the building's electrical grid, reducing electricity costs.

With our stylish cab design options and the ability to use custom features, you can extend your building design into your elevator.

Passengers will appreciate the eye-catching design combined with the smooth and quiet ride.

To enhance synergy, you can add AGILE, our innovative family of elevator enhancers. AGILE includes four intelligent elements that make elevators smarter, get passengers to destinations faster, reduce building traffic and improve your building aesthetics. AGILE also includes features that boost building security and enhance your ability to manage building passenger movement.

# Remarkable ride quality powered by advanced technology

To achieve smooth and precise ride quality, synergy incorporates the latest code-compliant components. They work together for high-speed elevator performance, energy efficiency, reliability and passenger safety.

## **Controller**

Our powerful 32-bit microprocessor controller uses solid-state technology, boosting elevator reliability with a proven track record. The nonproprietary user interface tool (UIT) provides easy access to adjustments and parameters for maintenance and service.

## **Regenerative drive**

Captures unused energy generated by the elevator and feeds it back into your building grid. It's compact and easy to maintain. For a more quiet and reliable operation, the motor and brake contactors are replaced with SIL3 solid-state devices on specific drive motors up to 60 horsepower. Our patented variable frequency (VVVF) drive motor offers smooth acceleration and deceleration. For buildings that cannot accept energy that's fed back, refer to your local sales representative.

## **Battery auto rescue operation (optional)**

In a power outage, elevator passengers are transported to the nearest floor, either up or down depending on the counterbalance of the car. Once the car is level at the floor, the doors will open so they can get out. This is an optional rescue system.

## **Machine**

Our permanent magnet machine delivers high performance, increased efficiency and reduced energy consumption, while eliminating the need for contaminating lubricants. It's located in the overhead to eliminate the need for a machine room.

## **Universal door operator**

The new linear door operator technology provides enhanced door reliability as well as quick, smooth door operation. It reduces the number of service calls due to malfunctioning doors.

## **Overslung design**

Helps provide better ride quality and performance.

## **Roller guides**

Quality guide systems are critical for elevator ride and performance.

Our high-quality, spring-loaded car roller guides ensure elevator car movement is smooth, quiet and ultra-precise.

## **Absolute positioning system**

Precisely measures your elevator's speed and positioning. This promotes accurate floor leveling, helping ensure passenger safety.

## **Chain compensation**

Chain compensation may be used or may be required to provide the appropriate counterbalance and equalize load distribution regardless of the car's hoistway position. Chain compensation is typically required on cars with over 110 feet of travel but speed, capacity or other option selections may eliminate the need.

The image shows the interior of an elevator cab. The walls are covered in vertical panels of Graystone plastic laminate, which have a light, neutral tone. The ceiling is white and features several recessed circular downlights. A horizontal handrail is visible on the right side of the cab. The floor is a light-colored wood-grain laminate. A black text box is overlaid on the bottom left of the image.

## SIMPLE YET SOPHISTICATED

Our cab and finish options let you personalize your elevator interior. Just like you want to.

Pictured above: Graystone plastic laminate vertical applied panels with downlight ceiling. Floors by others.

## Standard cab designs

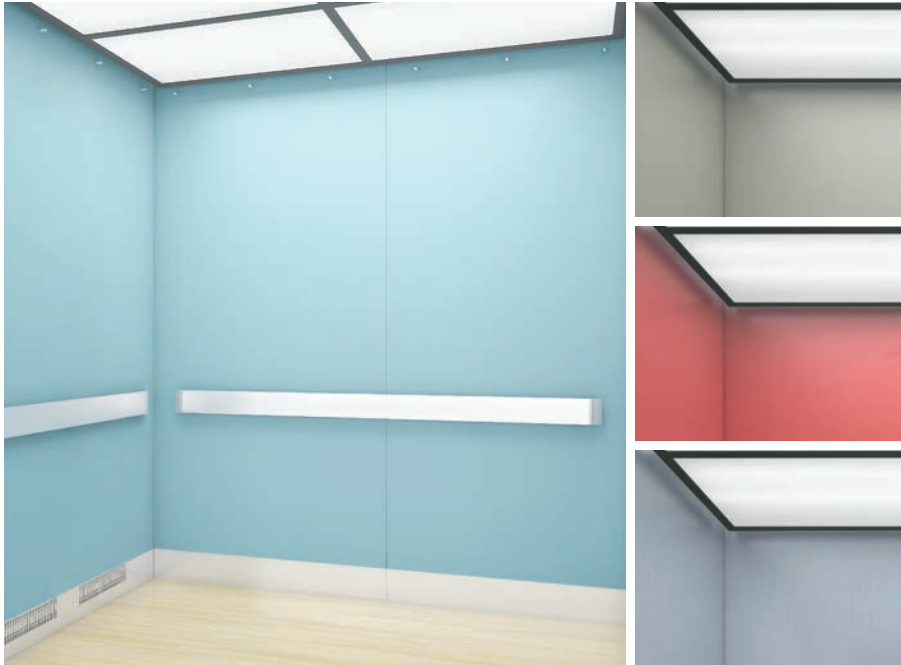

### Steel shell wall design

Clean and modern flat cab interior designs convey quality. Our durable formed steel shell cab is available in a variety of powder coat options or can be upgraded to brushed stainless steel.

## Upgraded cab designs

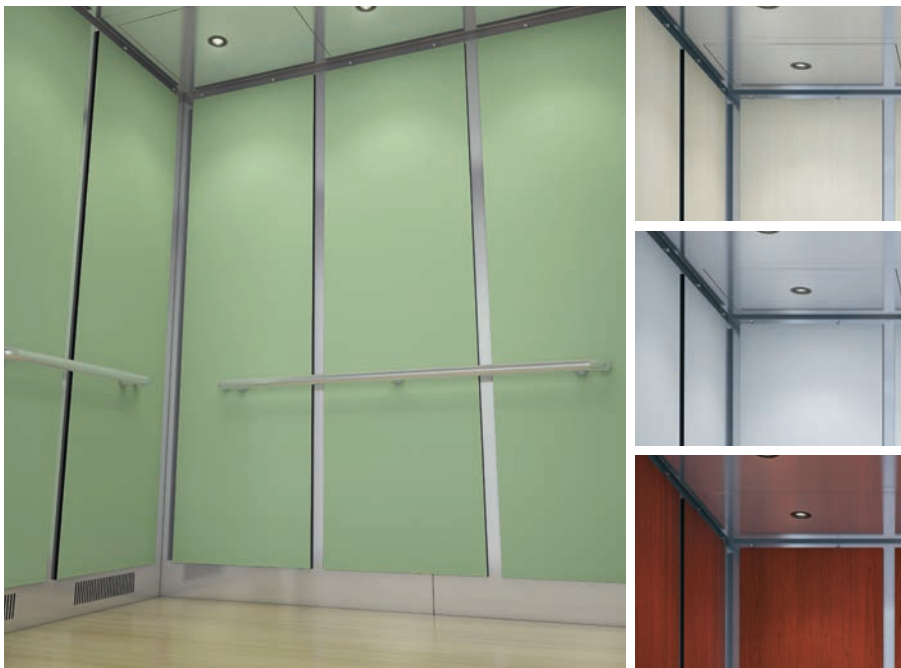

### Steel shell wall with applied panel design

Mix beauty and practicality with this decorative and durable cab. The panel design is constructed with a high-quality steel shell and vertical or horizontal raised panels made with a core of urea formaldehyde-free particle board.

# FINISHES





## Plastic laminates

### Woods

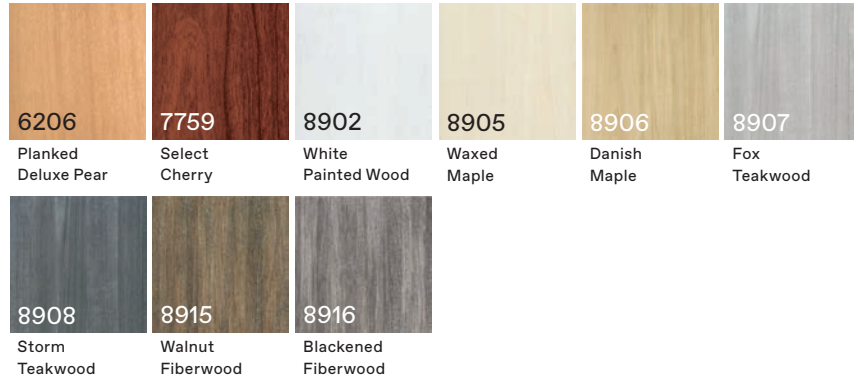

### Solids

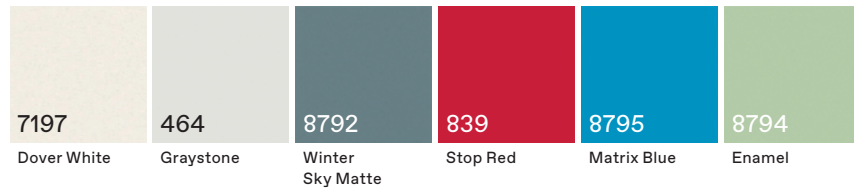

### Patterns

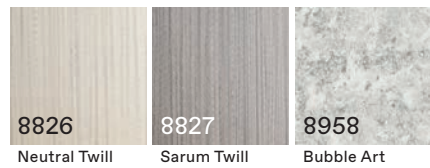

## Powder coats



## Metals



 Refer to the Cab Finishes Guide for further information. Colors may vary. We recommend examining a large color selector sheet before making a selection. Some metal finish options are only available in limited applications. Contact your local representative for details

# Fixtures and accessories

## Traditional fixtures

### Product details

- Faceplates in bronze, brushed or polished stainless steel
- Position indicator displays car location



Combo hall lantern and position indicator with directional arrows



Intermediate hall lantern with arrows



Intermediate hall station



Intermediate hall station with fire services devices



Push button available in blue, white, red and green LED lighting



Car operating panel

## Vandal-resistant fixtures

### Product details

- Faceplates in bronze, brushed or polished stainless steel
- Metal push buttons and durable car riding lanterns
- Pry-resistant hall jamb symbols and buttons



Combo hall lantern and position indicator with directional arrows



Intermediate hall lantern with arrows



Terminal hall station



Intermediate hall station with fire services devices



Push button available in red, blue, white and green LED lighting



Car operating panel

## Ceilings



### Basic flat

Exposed cab top with optional recessed lighting.



### Suspended

White translucent diffusers with ceiling frames.



### Downlight

Metal pan downlight ceiling features LED lighting with six or nine lights (based on cab size.)

## Handrails

### Cylindrical

1½" cylindrical handrail is a continuous metal form with ends turned toward the wall. We also offer straight end caps. Comes in stainless steel finish.



### Flat bar

Metal bar handrail is available in ¼" thickness and 2", 4" or 6" widths. Comes in stainless steel finish.



## Sills

Our cab sill finishes allow you to match your sills to any other design component inside the cab.



### Aluminum



### Nickel silver



### Bronze

# Entrance and return options

## Hoistway and door entrance finishes

Typically, the entrance frame would match the door selection, but nothing says you have to. Choose from any powder coat color or metal finish.

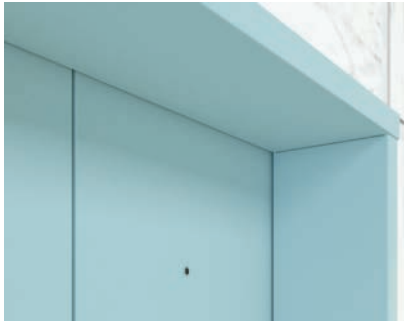

**Powder coat finish**  
T-style entrance frame in Blue Patina powder coat.



**Metal finish**  
T-style entrance frame in #4 Brushed Stainless Steel.

### Braille plates



- Option 1: Resin braille plate
- Option 2: Surface mount cast braille plate
- Option 3: Flush (inlaid) mount cast braille plate

Door orientation options offer a range of benefits to accommodate different project needs.

### One-speed

The most economical door offering, available with either right- or left-hand opening. (right-hand shown)

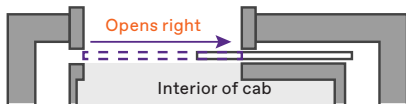

### Two-speed

Provides a wider opening without compromising door cycling time. Two doors move in the same direction, one sliding faster than the other. Available with either right- or left-hand opening. (right-hand shown)

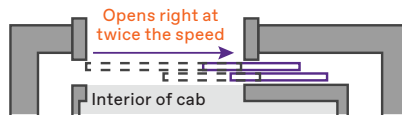

### Center opening

Best for high traffic buildings. Permits the quickest entry and exit, improving elevator service while giving an attractive, symmetrical appearance.

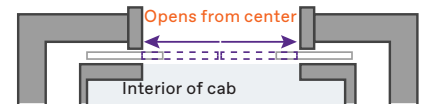

## Front returns

### Wrap-around returns

This return features a hinged car operating panel and separate filler panel. Comes standard.



### Column returns

This return features a hinged car operating panel secured to the filler panel and aligned vertically with the column.



### Full-width wrap-around returns

This return features a hinged car operating panel with integral column and filler panel. The swing extends from the cab opening to the cab wall.



Fixtures shown on this page are for representation only. Your project-specific application may vary.

Front returns include the car station, return panel, signal fixtures and head jamb. Images above represent return types in brushed stainless steel.

# PLANNING

## synergy elevator applications



Passenger elevator



Service elevator

### The numbers at a glance

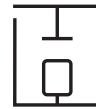

Type  
Building Supported



Travel  
Up to 300'-0"



Capacity  
2100 – 5000 lbs



Speed\*  
200 – 500 fpm

### synergy Technical Specifications

|                       |   |
|-----------------------|---|
| Speeds (fpm)          | 200, 350, 500 feet per minute<br>(dependent on project-specific conditions, such as capacity).        |
| Maximum travel        | 300'-0" with standard overhead and pit depth  |
| Power characteristics | 200-480 VAC, 3 phase, 60 hertz  |
| Controller            | TAC32T  |
| Door operator         | Universal Door Operator   |
| Auto rescue           | Only standard on the energy efficient drive motor up to 60 hp. Not applicable on standard 10K option. |

# Passenger elevators

## Standard and performance

Side view  
Front opening

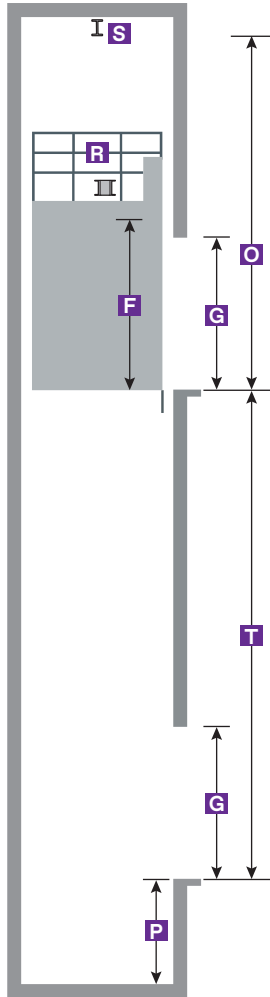

Side view  
Front and rear opening

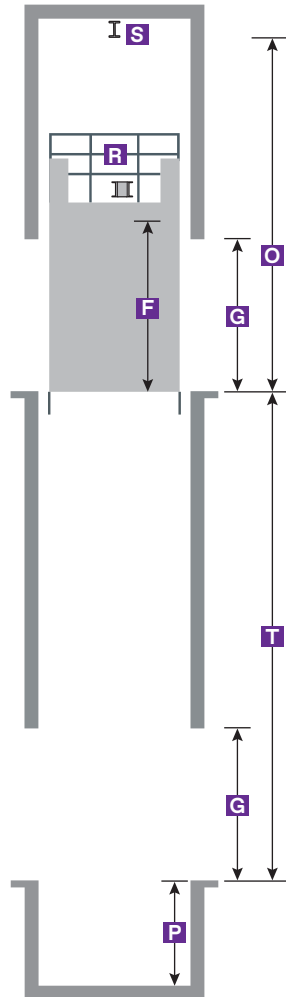

- A** Hoistway width
- B** Hoistway depth
- C** Inside clear width
- D** Inside clear depth
- E** Door clear width
- F** Inside clear height
- G** Door clear height
- O** Minimum overhead
- P** Minimum pit depth
- R** Car top railing
- S** Safety beam
- T** Travel

### One-speed center opening doors

Top view:  
Front opening

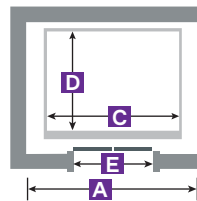

Top view:  
Front and rear opening

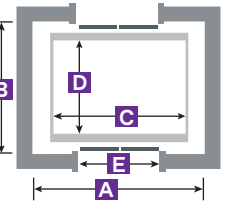

### One-speed side opening doors

Top view:  
Front opening

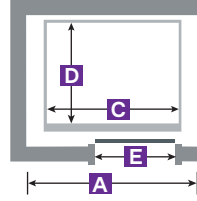

Top view:  
Front and rear opening

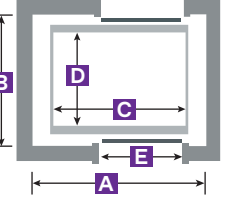

- O** Minimum overhead:<sup>1</sup>  
200 fpm: 16'-0" (for front-opening  
2100–4000 lbs capacities only),  
16'-6" (for front/rear-opening  
2100–3500 lbs capacities only)  
350 fpm: 16'-4"  
500 fpm: 17'-6"

- P** Minimum pit depth:<sup>6</sup>  
200 fpm: 5'-0"  
350 fpm: 5'-5"  
500 fpm: 6'-6"

- S** Safety beam required  
per OSHA 1926.502<sup>6</sup>

- T** Max travel possible:  
300'-0"<sup>1</sup>

### Passenger elevators

| Capacity (lbs)    | Hoistway <sup>5,9</sup> A x B | Front/rear | Inside clear C x D | Door type | Door width E |
|-------------------|-------------------------------|------------|--------------------|-----------|--------------|
| 2100 <sup>2</sup> | 7'-4" x 6'-8" <sup>4</sup>    | F          | 5'-8" x 4'-3"      | One-speed | 3'-0"        |
| 2500              | 8'-4" x 6'-8" <sup>4</sup>    | F          | 6'-8" x 4'-3"      | One-speed | 3'-6"        |
| 2500              | 9'-2" x 6'-8¼" <sup>5</sup>   | F/R        | 6'-8" x 4'-3½"     | One-speed | 3'-6"        |
| 3000              | 8'-4" x 7'-2" <sup>4</sup>    | F          | 6'-8" x 4'-9"      | One-speed | 3'-6"        |
| 3000              | 9'-2" x 7'-2¼" <sup>5</sup>   | F/R        | 6'-8" x 4'-9½"     | One-speed | 3'-6"        |
| 3500 <sup>3</sup> | 8'-4" x 7'-10" <sup>4</sup>   | F          | 6'-8" x 5'-5"      | One-speed | 3'-6"        |
| 3500 <sup>3</sup> | 9'-2" x 7'-10¼" <sup>5</sup>  | F/R        | 6'-8" x 5'-5½"     | One-speed | 3'-6"        |
| 4000 <sup>3</sup> | 9'-4" x 7'-10" <sup>4</sup>   | F          | 7'-8" x 5'-5"      | One-speed | 3'-6"/4'-0"  |

Contact your local representative for various code or jurisdictional exceptions, or alterations required. See endnotes on page 15.

# Service elevators

Side view  
Front opening

Side view  
Front and rear opening

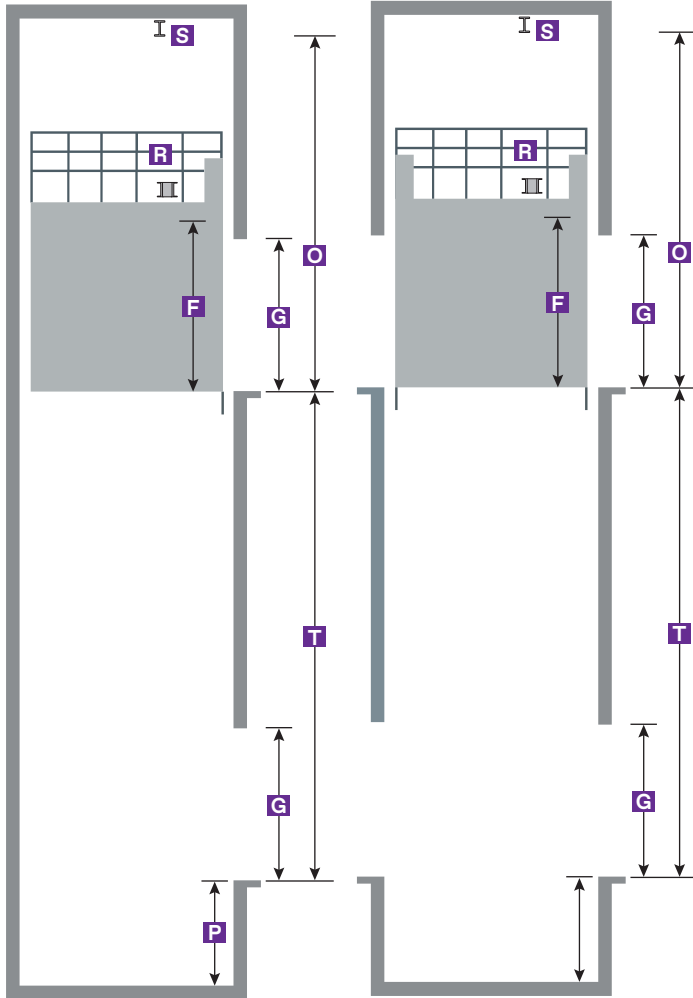

- A** Hoistway width
- B** Hoistway depth
- C** Inside clear width
- D** Inside clear depth
- E** Door clear width
- F** Inside clear height
- G** Door clear height
- O** Minimum overhead
- P** Minimum pit depth
- R** Car top railing
- S** Safety beam
- T** Travel

## Two-speed side opening doors

Top view:  
Front opening

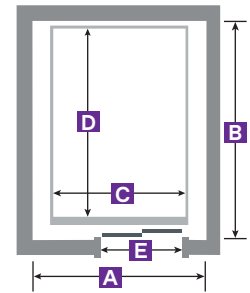

Top view:  
Front and rear opening

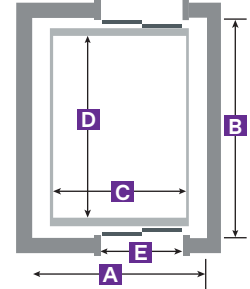

| Service elevators |                               |            |                    |           |                           |
|-------------------|-------------------------------|------------|--------------------|-----------|---------------------------|
| Capacity (lbs)    | Hoistway <sup>5,9</sup> A x B | Front/rear | Inside clear C x D | Door type | Door width <sup>8</sup> E |
| 4500              | 8'-2" x 9'-8" <sup>5</sup>    | F          | 5'-8" x 7'-9½"     | Two-speed | 4'-0"/4'-6"               |
| 4500              | 8'-2" x 10'-9¼" <sup>5</sup>  | F/R        | 5'-8" x 7'-10"     | Two-speed | 4'-0"/4'-6"               |
| 5000              | 8'-2" x 10'-2" <sup>5</sup>   | F          | 5'-8" x 8'-5"      | Two-speed | 4'-0"/4'-6"               |
| 5000              | 8'-2" x 11'-4¾" <sup>5</sup>  | F/R        | 5'-8" x 8'-5½"     | Two-speed | 4'-0"/4'-6"               |
| 5000H             | 8'-2" x 10'-9" <sup>5</sup>   | F          | 5'-8" x 9'-0"      | Two-speed | 4'-0"/4'-6"               |
| 5000H             | 8'-2" x 11'-11¼" <sup>5</sup> | F/R        | 5'-8" x 9'-0½"     | Two-speed | 4'-0"/4'-6"               |

**F** Inside clear height: 7'-4" <sup>1</sup>

**G** Door clear height: 7'-0"

**O** Minimum overhead: <sup>1</sup>  
 200 fpm: 16'-4"  
 350 fpm: 16'-4"  
 500 fpm: 17'-6"

**P** Minimum pit depth: <sup>6</sup>  
 200 fpm: 5'-0"  
 350 fpm: 5'-5"  
 500 fpm: 6'-6"

**S** Safety beam required per OSHA 1926.502 <sup>6</sup>

**T** Max travel possible: 300'-0"

# Controller rooms

If your project will not allow for an in-jamb controller installation, a control room space may be needed. The features of your system determine the controller room you'll need.

The controller room includes space for the controller, disconnect and transformer. The most desirable controller room location is on the top floor served, adjacent to the elevator hoistway.

At an additional cost, it may be located remotely, but must be within 150 feet of wire length from motor to controller.

## Controller room dimensions <sup>10</sup>

| Size    | A      | B      | C     |
|---------|--------|--------|-------|
| Simplex | 5'-0"  | 5'-11" | 3'-0" |
| Duplex  | 10'-0" | 5'-11" | 3'-0" |

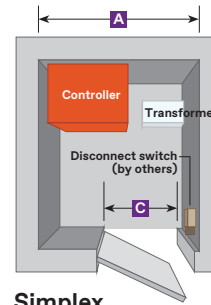

Simplex

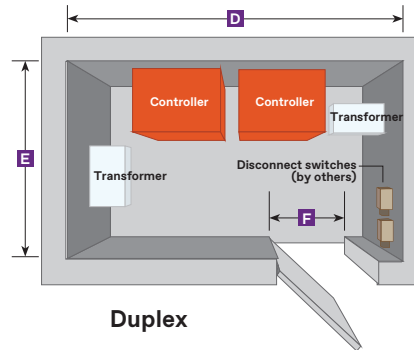

Duplex

## Support Configuration

Our synergy MRL traction elevators is building supported, requiring structural support by the building. As a result, this elevator is able to achieve faster speeds and higher capacities.

### Building supported connection details

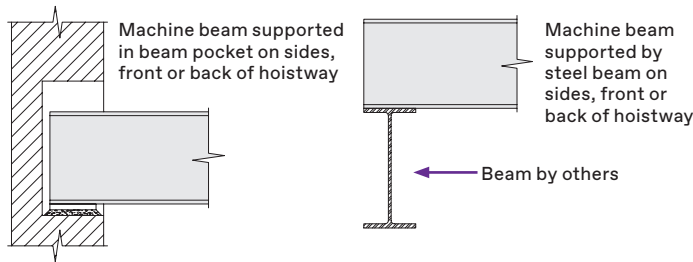

### Building supported configuration is ideal for:

- Steel, concrete or other construction methods capable of carrying the loads of an elevator system.
- Buildings with travel distance up to 300'-0".
- Elevators with capacities up to 5000 lbs and speeds up to 500 fpm.
- Standard and upgraded finishes and flooring.

## Endnotes

Dimensional data shown is for both seismic and nonseismic conditions and complies with current ASME A17.1 and CSA B44 Safety Code for Elevators. Local codes may vary from the national codes. Consult your TK Elevator representative for details.

- <sup>1</sup> Inside clear height available in 1" increments. Dimension shown is based on suspended ceiling design. An increase in cab height will result in an increase in overhead requirements.
- <sup>2</sup> This capacity is not available with 3'6" center opening doors; only left and right handed door. Center opening, single speed is available in 4'-0" doors.
- <sup>3</sup> To achieve IBC stretcher compliance, 2500, 3000, 3500 and 4000 car load capacities can accommodate an 84" ambulance stretcher. However, this is dependent on cab and door configurations. We also offer 4500 and 5000 lbs car capacities with no configuration restrictions. Contact your TK Elevator representative for details.
- <sup>4</sup> For Seismic conditions on all front and rear applications and all service elevators, add 4" to hoistway width and 2" to hoistway depth. Contact your local TK Elevator representative to evaluate the building location to determine the seismic requirement.

- <sup>5</sup> For Seismic conditions on all front and rear applications and all service elevators, add 7" to hoistway width.
- <sup>6</sup> Occupied space is allowed below pit, but increases minimum hoistway and clear overhead dimensions. Consult with your TK Elevator representative for increased dimensions.
- <sup>7</sup> Provided and installed by others, as directed by the local TK elevator office. Minimum controller space height is shown to the bottom of the safety beam.
- <sup>8</sup> With optional 4'-6" two-speed side opening door, hoistway width remains 8'-2".
- <sup>9</sup> For multiple elevators: Add 4" for a divider beam between hoistways.
- <sup>10</sup> Controller room temperature range 32°F minimum, 104°F maximum. 10-95% non-condensing relative humidity.

TK Elevator Corporation  
788 Circle 75 Parkway SE  
Suite 500  
Atlanta, GA 30339  
P: +1 844 427 5461  
www.tkelevator.com/us



INTERNATIONAL  
**LIVING FUTURE**  
INSTITUTE™

All illustrations and specifications are based on information in effect at time of publication approval.  
TK Elevator reserves the right to change specifications or design and to discontinue items without prior notice or obligation.  
© 2022 TK Elevator Corporation. CA License #C11-651371 | 30030 | synergy product brochure